

Actuator and Sensor selection for feedback control of the linearised Ginzburg-Landau equation

S. Oehler, A. Ooi and S. J. Illingworth

Department of Mechanical Engineering
The University of Melbourne, Victoria 3010, Australia

Abstract

The process of selecting the optimal actuator and sensor location for feedback control of the linearized Ginzburg-Landau equation is considered. We inspect the problem for a single actuator and a single sensor, with a particular focus on how the optimal locations vary as the stability of the system, defined in a suitable way, is changed. By mapping the optimal actuator and sensor locations with varying system stability, a fundamental trade-off for this particular flow control problem is made clear. On the one hand, the actuator and sensor need to each ‘see’ enough of the modes they are trying to control; but on the other hand, they must also be close enough to each other so that the time lag, which is the time taken for the effect of the actuation to be seen at the sensor, is not too large. In particular, we will see that these two requirements are conflicting, and become increasingly so as the flow is made more unstable. Implications for effective feedback control with a single sensor and actuator are discussed.

Introduction

Hydrodynamic stability theory studies the stability of a fluid system, and it has been used to favourably alter the behaviour of fluid fields [5]. Altering the behaviour of a flow is known as flow control, which can either be passive, e.g. the modification of a surface profile, or active using some form of energy supplied via an actuator. The actuator requires an instruction first, which is supplied by a sensor further upstream. This is also called an open-loop control setup, where an actuator has no feedback on how well it performed, therefore it is necessary to know the exact dynamics of the flow.

Flow control based on control theory, which focuses on closed-loop dynamics, did not emerge until the late 1990’s. In this case the sensor is placed downstream of the actuator. The actuator uses the feedback signal from the sensor to adjust its behaviour accordingly, thus allowing to compensate for uncertainties, such as modelling errors or unknown disturbances. The processing of the received signal sent to the actuator is managed by a controller. The tools provided by control theory are essential when designing a functional controller, the ultimate goal of the design process. In flow control, selecting the optimal actuator and sensor type and position is also a crucial part of the design process, as they have a direct impact on how well the controller can perform. This paper aims to understand the physical limitations, such as time-lag between actuating and sensing, which can lead to a fluid system that is impossible to control, no matter how sophisticated a controller is.

Bagheri et al. [2] presented a general framework for closed-loop flow control studies, based on the Ginzburg-Landau equation, which will be employed for this paper. The Ginzburg-Landau equation has been the subject of various studies involving fluid instabilities in spatially developing flows [8]. The framework of Bagheri et al.’s review was based on a model employed by Chomaz et al. [4]. Chen and Rowley [3] used this framework to implement a H_2 optimal controller, similar to Lauga and Bewley

[9], in combination with an iterative gradient-based minimisation algorithm used by Hiramoto et al. [7] to find the the best actuator and sensor position for a given flow.

The Ginzburg-Landau equation and controller design are introduced in §*The complex Ginzburg-Landau Equation and its Control*, which follows the work of Bagheri et al. and Chen and Rowley closely. We will show how control changes as the stability of the system is varied in §*Results*. §*Discussion* and §*Conclusions* will discuss and summarize the findings and give recommendations for future control design.

The complex Ginzburg-Landau Equation and its Control

The Ginzburg-Landau Equation is used to model many of the phenomena occurring in fluid systems for a one-dimensional spatial domain along the stream-wise direction. A comprehensive review of the Ginzburg-Landau equation is given by Bagheri et al. [2]. Defined on an infinite interval, $-\infty < x < \infty$, the linearised complex Ginzburg-Landau Equation is:

$$\frac{\partial q(x,t)}{\partial t} = \left(-v \frac{\partial}{\partial x} + \gamma \frac{\partial^2}{\partial x^2} + \mu(x) \right) q(x,t) = \mathcal{A}q(x,t) \quad (1)$$

Where $q(x,t) < \infty$, as $x \rightarrow \pm\infty$, is the perturbation of the flow, and \mathcal{A} is the Ginzburg-Landau operator; the boundary conditions are $q(x,0) = q_0(x)$. The convective and the dissipative nature of the flow are represented by the complex terms $v = U + 2ic_u$ and $\gamma = 1 + ic_d$, respectively. Dispersion is introduced into the flow, when both c_u and c_d are non-zero, which will affect the perturbation velocity, defined as $U_{max} = U + 2c_u c_d$. The extra real-valued term $\mu(x) = \mu_0 - c_u^2 + \mu_2 x^2 / 2$ models exponential instabilities. These instabilities will cause an unstable region, where perturbations are amplified, when $\mu(x) > 0$, which occurs for $|x| < \sqrt{-2(\mu_0 - c_u^2) / \mu_2}$. The system turns unstable once the real part of most unstable eigenvalue becomes positive ($\lambda_0 > 0$). This occurs when $\mu_0 > \mu_c$, where μ_c is the critical parameter for globally instabilities. The flow is called convectively unstable, while $0 < \mu_0 < \mu_c$. It has an unstable region, but the advection is strong enough to convect all disturbances downstream before they can become too large, and as a result no mode is unstable. In this case the least stable modes will exhibit transient growth, where they perturbations will initially grow, but then slowly decay.

For the complex Ginzburg-Landau equation an analytical solution exists, from which the eigenvalues (λ_n), eigenmodes (ϕ_n) and adjoint modes (ψ_n) can be generated:

$$\lambda_n = \mu_0 - c_u^2 - v^2 / (4\gamma) - (n + 0.5)h \quad (2a)$$

$$\phi_n = \exp \left[0.5 \left(vx / \gamma - (\chi x)^2 \right) \right] H_n(\chi x). \quad (2b)$$

$$\psi_n = \exp \left[-\bar{v}x / \bar{\gamma} \right] \bar{\phi}_n(x). \quad (2c)$$

Where $h = \sqrt{-2\mu_2\gamma}$, $\chi = (-\mu_2/(2\gamma))^{0.25}$, $n = 0, 1, \dots, N-1$, H_n is the n th Hermite polynomials and $(\cdot)^*$ is the complex conjugate. An actuating force u is applied at $x = x_a$, which is employed with a Gaussian window of variance σ to achieve a more realistic actuating. An external white noise disturbance d is also included, so that the equation becomes:

$$\dot{q}(x, t) = \mathcal{A}q(x, t) + \exp(-((x - x_a)/\sigma)^2)u(t) + d(x, t) \quad (3)$$

Knowing all the perturbations is not the case for most control systems. A single sensor is placed at $x = x_s$, including a Gaussian window, reading the integrated perturbation signal, which is contaminated by white sensor noise n :

$$y(t) = \int_{-\infty}^{\infty} \exp(-((x - x_s)/\sigma)^2)q(x, t) + n(t) \quad (4)$$

Discretisation

The complex Ginzburg-Landau Equation is discretised along the spatial domain using Hermite polynomials: $\dot{q} = Aq$, where A is the discretised version of the Ginzburg-Landau operator \mathcal{A} . Expressed in state space form:

$$\dot{q} = Aq + Bu + W^{1/2}d \quad (5a)$$

$$y = Cq + V^{1/2}n \quad (5b)$$

Where $u \in \mathbb{R}$, $d \in \mathbb{R}$, $n \in \mathbb{R}$ and $y \in \mathbb{R}$ are vectors of inputs and outputs; d and n are set to be white noise signals with covariance $E(d^T d) = I$ and $E(n^T n) = I$. B and C are suitably dimensioned matrices, representing the actuator and sensor, while $W^{1/2}$ and $V^{1/2}$ are scaling factors of the white noise signals. $A \in \mathbb{C}^{N \times N}$ is the state matrix, and $q(t) \in \mathbb{R}^N$. A resolution of $N = 247$ discrete points is chosen, which ensures that the model is converged for all setups in this paper.

H_2 optimal control

To control the system, a controller K has to be implemented, but before we can proceed, it is necessary to define a measure of control first, such that it is possible to define how well the closed-loop system is performing. In this case it is desired to minimise the perturbation magnitude $\int_{-\infty}^{\infty} |q(x, t)|^2$ by finding the optimal relationship from $y(t)$ to $u(t)$, where $u(t) = Ky(t)$. At the same time we want to bound the size of $|u(t)|^2$ to avoid infinitely large actuator magnitudes. Therefore we define a cost function, J , which represents a weighting of the two signals:

$$J = E \left\{ \lim_{T \rightarrow \infty} \frac{1}{T} \int_0^T \left(\beta^2 \int_{-\infty}^{\infty} |q(x, t)|^2 dx + \alpha^2 |u(t)|^2 \right) dt \right\} \quad (6)$$

Where β and α are weighting terms and E is the expected value. This can be expressed in discrete vector format as:

$$J = E \left\{ \lim_{T \rightarrow \infty} \frac{1}{T} \int_0^T (q^* Q q + u^* R u) dt \right\} \quad (7)$$

Where $Q = \beta^2 M \geq 0$, $R = \alpha^2 I > 0$, and $M \in \mathbb{R}^{N \times N}$ is a trapezoidal integration operator. We can define individual cost operators $J_1 = Q^{1/2} q$ and $J_2 = R^{1/2} u$:

$$J = E \left\{ \lim_{T \rightarrow \infty} \frac{1}{T} \int_0^T (J_1^* J_1 + J_2^* J_2) dt \right\}; \quad z = \begin{bmatrix} J_1 \\ J_2 \end{bmatrix} \quad (8)$$

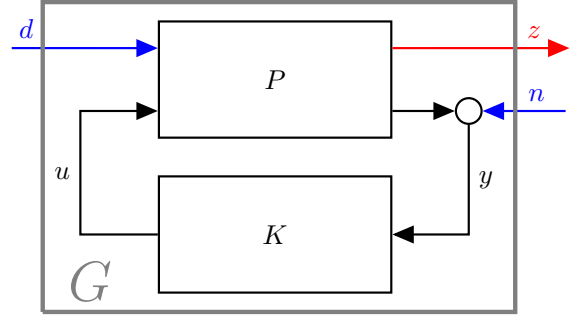

Figure 1: Block-Diagram of the transfer function G , with P representing the plant and K the controller. The inputs are d and n (blue) and the output is z (red).

Based on the cost function it is possible to find K , such that J is minimised using Linear Quadratic Gaussian (LQG) control.

We want to quantify how well our controller is working when disturbances are applied. A transfer function G is introduced, which relates the gain provided by the external inputs d and n to the weighted signals (z) over all frequencies: $z = G(j\omega) [d \ n]^T$, shown in figure 1, where P is the plant and K the controller that we want to design. Taking the transfer function 2-norm of the G is a sensible measure of how big the output will be, and therefore how well the controller is performing:

$$\gamma_2 \triangleq \|G\|_2 \triangleq \sqrt{\frac{1}{2\pi} \int_{-\infty}^{\infty} \text{tr}(G^*(j\omega)G(j\omega)) d\omega} \quad (9)$$

Simulation parameters

The parameters chosen are shown in table 1, which represent the supercritical setup used in Chen and Rowley [3], where the first mode is just unstable. The width of the Gaussian window, such that the function has fallen to 10% of its peak, is about 1.7, for the selected variance (σ) of the actuator and sensor.

In this case the first mode is just globally unstable, i.e. $\Re(\lambda_0) > 0$, while all other modes are stable. This setup has an unstable region between $-8.6 < x < 8.6$. The μ_0 parameter can be varied to decrease or increase the stability of the setup. Global instability is obtained when $\mu_0 > \mu_c = 0.397$. External disturbances are scaled with $W^{1/2} = I$; a small sensor noise $V^{1/2} = 2 \times 10^{-4} I$ is selected, ensuring well-posedness of the LQG controller, while minimising the effect of sensor noise.

Simulation parameters								
U	c_u	c_d	μ_0	μ_2	U_{max}	σ	α	β
2	0.2	-1	0.41	-0.01	1.6	$0.4\sqrt{2}$	1	7

Table 1: Parameters for the complex Ginzburg-Landau equation

Actuator and Sensor Placement

With the established framework in place to find an optimal controller for a given actuator and sensor position (x_a, x_s) , we now want to find their best position in the flow, so that optimal control can be achieved. Previous studies [1, 2] have placed the actuator at the peak of the most unstable adjoint mode (ψ_0) and the sensor at the peak of the most unstable global mode (ϕ_0) for their system. Those are the positions where actuating and sensing are most effective. Figure 2 shows the most unstable adjoint mode and global mode, peaking at $x = \{-7, 28, 7.28\}$ respectively, using the supercritical setup for the complex Ginzburg-

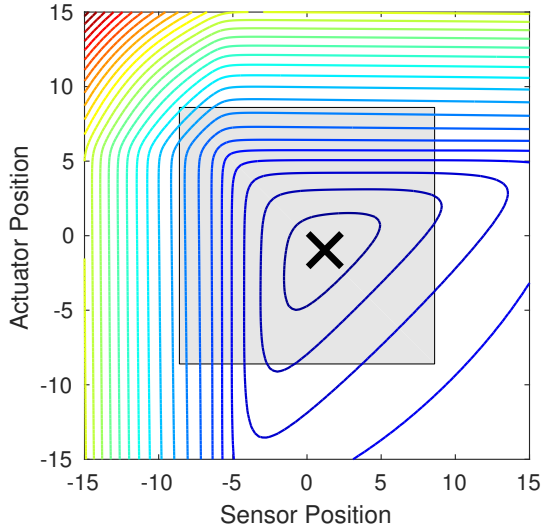

(a) Optimal placement for $\mu_0 = 0.41$:
 $\{x_a = -1.130, x_s = 1.062\}, \gamma_2 = 38.5$.

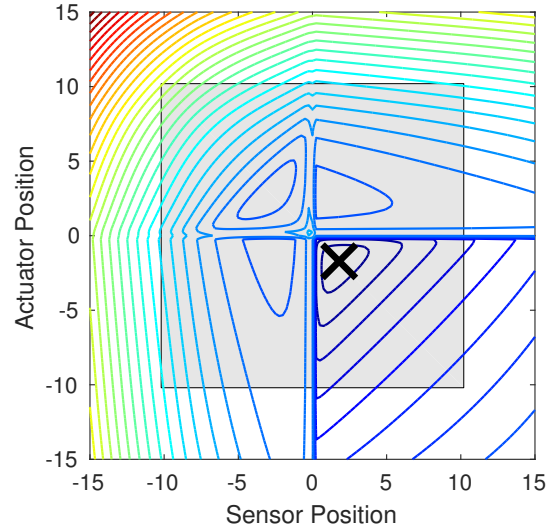

(b) Optimal placement for $\mu_0 = 0.56$:
 $\{x_a = -1.717, x_s = 1.688\}, \gamma_2 = 66.7$.

Figure 3: Contours of $\log_{10} \gamma_2$ for $\mu_0 = \{0.41, 0.56\}$, where the innermost contour is $\log_{10} \gamma_2 = \{1.75, 2\}$, and each subsequent contour increments by 0.25. The grey area represents the unstable region and optimal placement is shown at (\times)

Landau equation. Giannetti and Luchini [6] take a different approach, where they use the wavemaker region of the first mode to place the actuator and sensor. The wavemaker region, which represents the degree of overlap of the adjoint and global mode, is shown by the dashed blue line in figure 2, where the ideal position would be at the centre, $\{x_a = x_s = 0\}$.

Hiramoto et al. [7] use an iterative gradient-minimisation technique, which considers the differential of the controlled system's H_2 -norm with respect to x_a and x_s to find their best location for optimal control. This algorithm was improved and applied to the Ginzburg-Landau equation by Chen and Rowley [3]. They found an optimal position of $x_a = -1.03$ and $x_s = 0.98$, with $\gamma_2 = 46.1$ for the supercritical setup. Both results lie between the result of the wavemaker and the adjoint-global-mode approach. Chen and Rowley concluded that excessive time lag has a detrimental effect on perturbation control, and therefore the optimal result is closer to the wavemaker region, compared to the optimal position for actuating and sensing, when considered separately. They therefore proposed placing the actuator and sensor near the origin in the wavemaker region as an initial condition for iterative function minimisation.

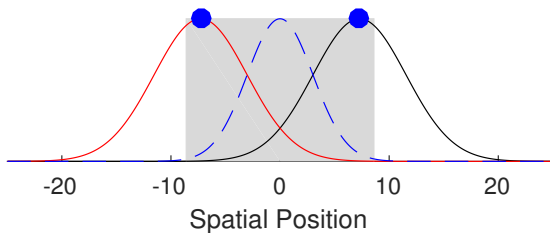

Figure 2: The first global (ϕ_0) and adjoint (ψ_0) eigenmode, represented by the black and red line respectively (see also equation 2). Their peaks are represented by the blue dots and their overlap by the dashed blue line (wavemaker region). The unstable domain is shaded grey.

Results

We now consider how the optimal actuator and sensor positions vary as we vary the stability of the flow. We will first map out γ_2 over a range of actuator-sensor positions, $\{-15, -14.75, \dots, 15\}$, in order to show how γ_2 varies with the actuator-sensor arrangement (figure 3). This is done for the supercritical setup ($\mu_0 = 0.41$), such that we can validate the result with previous studies, and repeated for a case where the second mode is supercritical ($\mu_0 = 0.56$). Finally we will employ the gradient-minimisation algorithm to find the optimal positions $\{x_a, x_s\}$, as the stability decreases ($-0.01 \leq \mu_0 \leq 0.71$). This range of μ_0 corresponds to a stable system ($\mu_0 = -0.01$) through to a system with three unstable modes ($\mu_0 = 0.71$). The mode-shapes are not affected by changing the criticality parameter μ_0 , therefore figures 2 and 4 are valid for all cases.

Figure 3a maps the variation of γ_2 for the supercritical case, which was also presented by Chen and Rowley [3]. Chen and Rowley pointed out that a penalty exists for placing the actuator too far downstream; for placing the sensor too far upstream; and for placing the actuator and sensor too far away from each other, which increases the time lag of the feedback loop. This results in the controller acting on outdated information, which has a detrimental affect on control performance. The optimal position for this setup is at $x_s \approx -x_a \approx 1$. This represents a trade-off between 'seeing' enough of the unstable mode on the one hand; and the corresponding time lag between actuation and sensing on the other hand.

Figure 3b repeats figure 3a for a larger value of μ_0 . This reduces stability by increasing the growth rate and by widening the unstable domain. In this case the actuator and sensor have to be placed farther away from each other for optimal control. Intuitively this is reasonable because the unstable domain is wider. The size of γ_2 has increased, which indicates a more challenging control problem, and which can be partly explained by the larger time-lag. A 'cliff' is observable in the contour plot near $\{x_a \approx 0, x_s > 0\}$ and $\{x_s \approx 0, x_a < 0\}$. In this case mode 2 (figure 4) is unstable, and controlling it is unavoidable for stability.

Both the second adjoint and global mode have zero magnitude when $x = 0$, therefore when placing the actuator or sensor at the origin, actuating or sensing of the second mode becomes very challenging. One may ask why control does not become impossible in this case? The answer is that both the actuation and sensing have Gaussian profiles in space (see equations (3,4)), and therefore sensing and actuation occur not just at $x = 0$, but also in its vicinity.

The results in figure 5 show that the distance between the actuator and sensor continuously increases as μ_0 is increased, while the optimal γ_2 achieved also increases. Increasing μ_0 does not affect the shape or position of the adjoint and global modes, but it does widen the unstable domain. Subsequent modes are further away from the centre, and a wider unstable domain will cover more of them. Eventually it will become impossible for a single-actuator single-sensor setup to cover all unstable modes, leading to an impossible control problem.

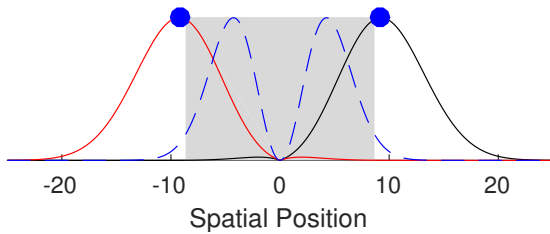

Figure 4: The second global (ϕ_1 , black line) and adjoint (ψ_1 , red line) eigenmode (see also equation 2). Their peaks are represented by the blue dots and their overlap by the dashed blue line. The unstable domain is shaded grey.

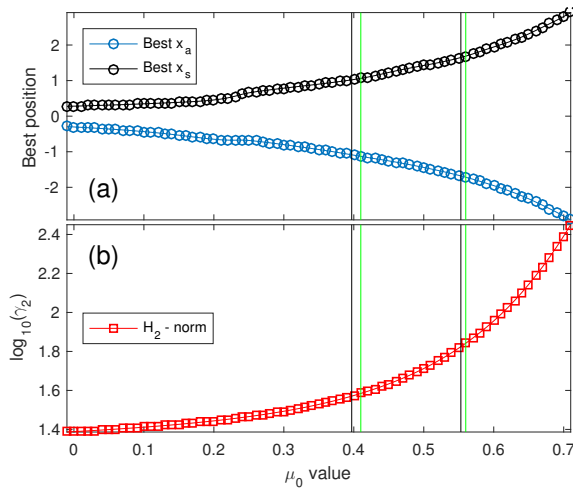

Figure 5: (a) Optimal placement for a range of μ_0 ; and (b) the corresponding H_2 -norm. The black lines show where the first and second mode become unstable. The green lines show the values used in figure 3.

Discussion and conclusions

There is an important trade-off underlying effective feedback control of the Ginzburg-Landau equation—at least when a single actuator and single sensor are used for control. On the one hand, the actuator and sensor must be placed in such a way that they each ‘see’ enough of any unstable or lightly damped modes. For the supercritical system this means placing the sensor near the peak of the first global eigenmode (which is where the mode is most observable); and placing the actuator near the

peak of the first adjoint eigenmode (which is where the mode is most controllable). This is indeed the approach to actuator and sensor placement taken in a number of previous studies. Crucially, there is a second and equally important consideration: that the single sensor and actuator are placed close enough to each other that the corresponding time lag is not excessively large. This second consideration has been less emphasized in the literature, with the notable exception of [3], who briefly comment on its importance.

Given the separation in space of the global and adjoint eigenmodes that one typically sees (see Figures 2 and 4), these two considerations are conflicting, and are more conflicting for higher modes whose global and adjoint eigenmodes are more well-separated in space. This leads to a fundamental trade-off when choosing the best position of the actuator and sensor—fundamental in the sense that it is driven by the underlying physics of the problem, and no controller, no matter how sophisticated, can avoid it.

The primary contribution of the present work is to make plain this trade-off by exploring the optimal actuator and sensor position as the stability of the system—and thus the number of the global and adjoint eigenmodes at different locations that need to be controlled—is varied. This is made most clear in figure 5, where we see that, as μ_0 is increased and the positions of the important global and adjoint eigenmodes become more spatially separated, i) the optimal actuator and sensor locations move further away from each other; and ii) the corresponding best control achieved—characterized by γ_2 —deteriorates.

References

- [1] Åkervik, E., Hoepffner, J., Ehrenstein, U. and Henningson, D. S., Optimal growth, model reduction and control in a separated boundary-layer flow using global eigenmodes, *J. Fluid Mech.*, **579**, 2007, 305–314.
- [2] Bagheri, S., Henningson, D. S., Hoepffner, J. and Schmid, P. J., Input-Output Analysis and Control Design Applied to a Linear Model of Spatially Developing Flows, *Appl. Mech. Rev.*, **62**, 2009, 020803.
- [3] Chen, K. and Rowley, C., H2 optimal actuator and sensor placement in the linearised complex GinzburgLandau system, *J. Fluid Mech.*, **681**, 2011, 241–260.
- [4] Chomaz, J. M., Huerre, P. and Redekopp, L., Models of hydrodynamic resonances in separated shear flows, in *6th Symposium on Turbulent Shear Flows*, 1987, 3–2, 3–2.
- [5] Gad-el Hak, M., Pollard, A. and Bonnet, J.-P., *Flow control: fundamentals and practices*, volume 53, Springer Science & Business Media, 2003.
- [6] Giannetti, F. and Luchini, P., Structural sensitivity of the first instability of the cylinder wake, *J. Fluid Mech.*, **581**, 2007, 167–197.
- [7] Hiramoto, K., Doki, H. and Obinata, G., Optimal Sensor/Actuator Placement for Active Vibration Control Using Explicit Solution of Algebraic Riccati Equation, *J. Sound Vib.*, **229**, 2000, 1057–1075.
- [8] Huerre, P. and Monkewitz, P. A., Local and global instabilities in spatially developing flows, *Annu. Rev. Fluid Mech.*, **22**, 1990, 473–537.
- [9] Lauga, E. and Bewley, T. R., Performance of a linear robust control strategy on a nonlinear model of spatially developing flows, *J. Fluid Mech.*, **512**, 2004, 343–374.